

Instruction Manual
for
Over Temperature
Alarm/Trip 1/4 DIN Controller
Relay Output
100 Ohm RTD Input
0-200 Deg. C.

CUSTOMER CONNECTIONS
for
SMART-3
1/4 DIN Controller
Relay Output

Controller Preset for
RTD Input
0-200 Degrees C

Alarm Output
Relay Contact - Output to Aux. Circuit (3 Amp 120/240VAC)
Connect to terminals #9 and #10 (N.O.)

100 Ohm RTD Input
Connect to terminals #19 and #20
(If three wire RTD probe - connect 3rd wire to terminal #17)

Connect 120VAC/240VAC
to terminals #1 and #2

Relay Contact - Trip Alarm (3 Amp 120/240VAC)
Connect to terminals #4 and #5 (N.O.)
Preset at 112 Deg. C

Note: (A) Trip Circuit - Alarm preset for High Alarm (AL1)
112 Deg. C

Note: (B) Alarm set point (SV)
preset at 90 Deg. C

Note:

These settings are where they are preset for shipping. Follow instructions for setting alarm temperature set point (SV) for alarm at desired temperature. It is preset for 90 Deg. C. The alarm temperature is entered on the lower display by using the arrow keypads per attached procedure-Press SHIFT KEY to change setting and use UP/DOWN keys to enter new value. To set Trip Temperature, use SET key to scan upper display to AL1 and set desired temperature on lower display by use of SHIFT KEY and UP/DOWN keys. Press SET key to enter new value into permanent memory. Trip preset at 112 Deg. C.

Description of Operation (Ref - Operating Flow Diagram)

Upper Display (PV) Displays the actual temperature as measured by the RTD sensor

Lower Display (SV) Displays the alarm temperature set point (preset at 90 deg. C)

To observe the trip temperature Set Point (AL1), press the SET key until upper display shows AL1 and the lower display will then indicate the trip set point temperature which is preset at 112 deg C. Continue to press SET key to return to normal PV and SV display.

Display Indication for Alarm Conditions

- A. Green LED on front of instrument. ON - Indicates temperature normal (below alarm temperature set point)
- B. Red LED on front of instrument. ON - Indicates over-temperature condition greater than trip temperature set point (AL1)

Note 1: Upper display (PV) will indicate 1nlE for open RTD probe.

Note 2: Upper display (PV) will indicate UUU1 for overrange - temperature greater than max range of 200 Deg. C.

Panel cut-out 3.75" x 3.75"

Initial Startup

When power is initially applied to controller, display will indicate the following:
type of thermocouple
Degree C or F

Then it will indicate the temperature range before transfer to PV display of actual process temperature and SV display of preset temperature setpoint.

If no thermocouple is connected to instrument, PV display will indicate:
Open thermocouple 1n1E
or UUU1 for actual temperature above set point range
(thermocouple burnout)

Panel Cutout

1/16 DIN Controller
1.772" square
Depth behind panel - 3.2 inches

Panel Cutout

1/4 DIN Controller
3.5" square
Depth behind panel - 3.2 inches

4. Operating Flow

4.1 Level 1 (User Level)

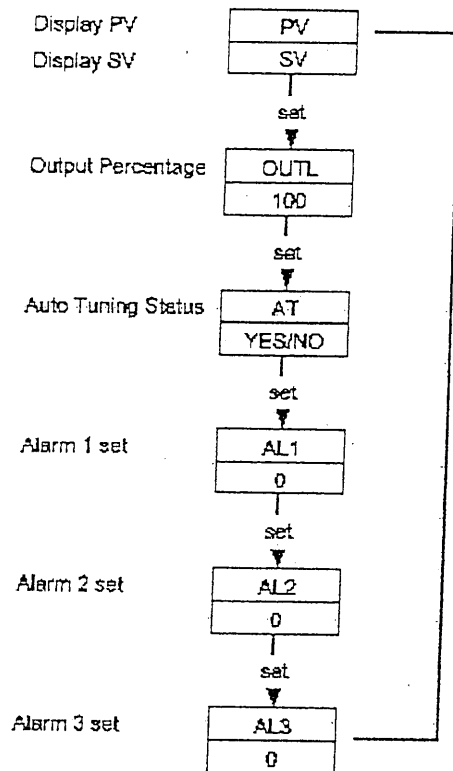

- 4.1.1 Press **SHIFT** key (\triangleleft) until the first digit begins to blink to input parameters, then press the **UP** key (\triangle) or **DOWN** key (∇) to increase or decrease value. Press the **SHIFT** Key (\triangleleft) again to go to the next digit. When all the numbers have been input, press **SET** key to enter the value.
- 4.1.2 **SET** key can also be used to change **MODEs**. If the **SET** key is pressed, the display shows the next **MODE**.

